



Since 2009

THE POWER BEHIND DISTRIBUTION

Catalog

www.adsmetal.com.tr



• Who are We?	3
• Our Facilities	4
• Global Capacity	5
• Product Group	6
• Production Process	20
• Our Approach to Quality	22
• Certificates and Approvals	23
• New Investment	24

Who are We?

ADS Metal is an industrial company specialized in the production of transformer tanks, corrugated walls, and related metal components for distribution and power transformers since 2009 in Ankara, Türkiye. With its advanced engineering infrastructure, high-tonnage production capacity, and strong operational capabilities, the company provides reliable and sustainable solutions to transformer manufacturers.

Our Facilities

22,900 m² of indoor

10,200 m² of outdoor



Global Capacity

4

FACTORIES

25+

COUNTRIES

4

CONTINENTS



Product Group



Power Transformer Tanks



HDG Transformer Tanks



Distribution Transformer Tanks

Product Group



Corrugated Walls



Cable Boxes



Conservatories Tanks

Power Transformer Tanks

Power transformer tanks are robust metal enclosures designed to house and protect the internal components of electrical power transformers, including the core, windings, and insulating oil. They provide mechanical strength and environmental protection against moisture, dust, corrosion, and external impacts. Depending on the transformer design, tanks may include radiators, conservators, bushings, and pressure relief devices to support cooling and operational safety. Their construction and sealing are critical for ensuring long-term reliability, insulation integrity, and safe operation in power transmission and distribution systems.

ADS Metal experienced teams produce power transformer tanks and auxiliary components with comprehensive technical specifications.

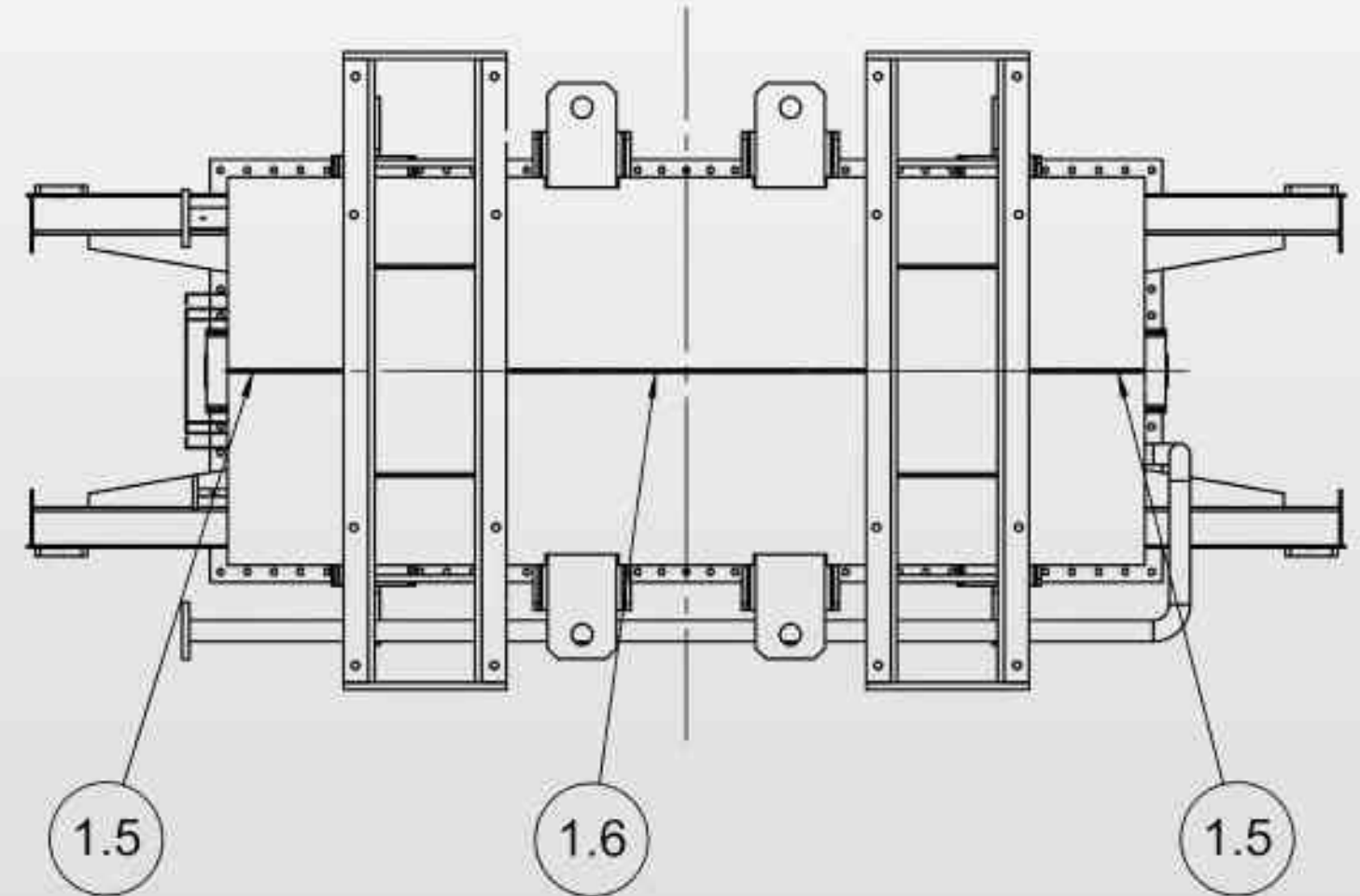

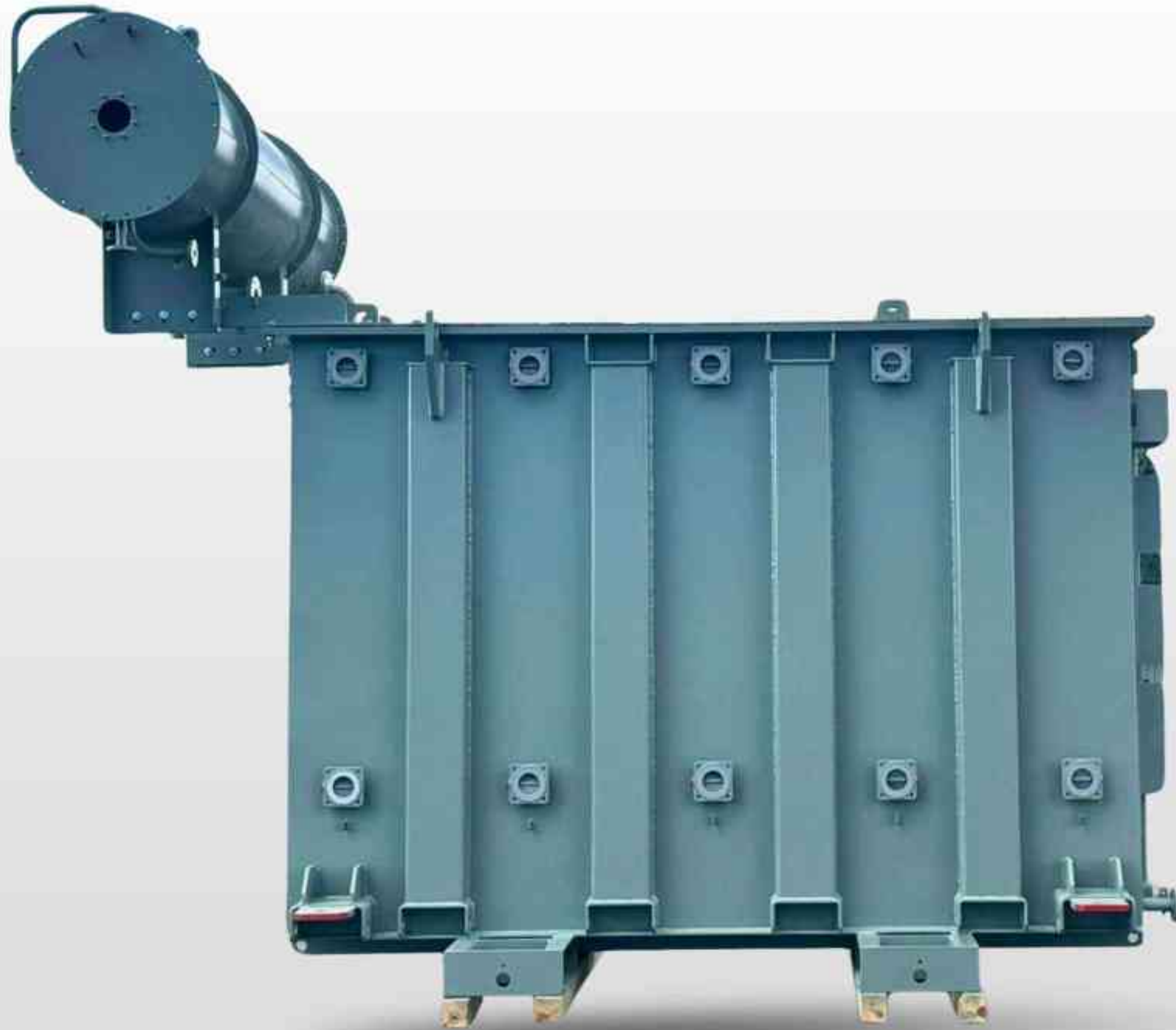

Material: S235JR, S235J0, S235J2, S355JR, S355J0, S355J2+N, SS304, SS316L

Surface Treatment: RAL color codes are specified by the customer, UL certified on demand coatings

Corrosion Protection: Coatings can be applied within the range of C3-L to C5-VH.

Welding Technique: MIG/MAG, TIG

Weight: Up to 40 tons

Capacity: 150 tons/month



Material: S235JR, S235J0, S235J2, S355JR, S355J0, S355J2+N, SS304, SS316L, DC01

Surface Treatment: RAL color codes are specified by the customer, UL certified on demand coatings

Corrosion Protection: Coatings can be applied within the range of C3-L to C5-VH.

Welding Technique: MIG/MAG, TIG

Weight: Up to 10 tons

Capacity: 500 tons/month

HDG Transformer Tanks

HDG (Hot-Dip Galvanized) transformer tanks are transformer enclosures coated with a protective zinc layer through the hot-dip galvanizing process to provide superior corrosion resistance. These tanks are especially suitable for outdoor and harsh environmental conditions such as high humidity, coastal areas, and industrial environments. The galvanized coating protects the steel surface against rust and extends the operational lifespan of the transformer tank with minimal maintenance requirements. They are widely preferred in power distribution and infrastructure projects requiring long-term reliability.

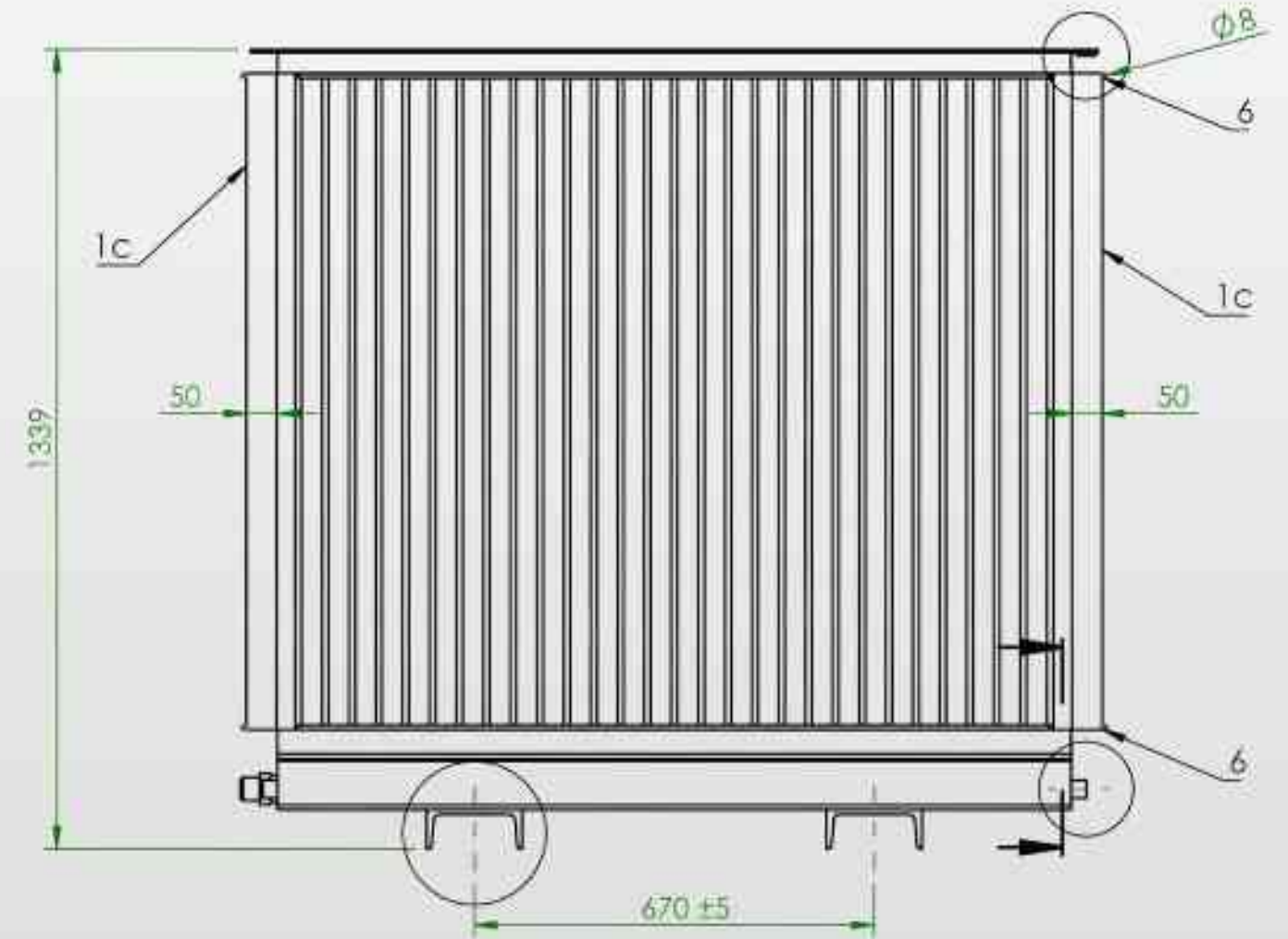



Material: S235JR, S235JO, S235J2, S355JR, S355JO, S355J2+N, SS304, SS316L, DC01

Surface Treatment: RAL color codes are specified by the customer, UL certified on demand coatings

Corrosion Protection: Coatings can be applied within the range of C3-L to C5-VH. ISO 1461 production standards are applied

Welding Technique: MIG/MAG, TIG

Dimensions: 2200 x 1830 x 2000 mm

Capacity: 20 tons/month

Corrugated Walls

Corrugated walls are specially formed metal panels used in transformer tanks to provide both structural flexibility and efficient cooling performance. Their corrugated shape increases the surface area of the tank, allowing heat generated inside the transformer to dissipate more effectively into the surrounding environment. In addition to cooling, corrugated walls compensate for oil volume expansion and contraction caused by temperature changes, reducing the need for a separate conservator system in many transformer designs. They are manufactured through precision forming and welding processes to ensure mechanical strength, leak tightness, and long-term durability.

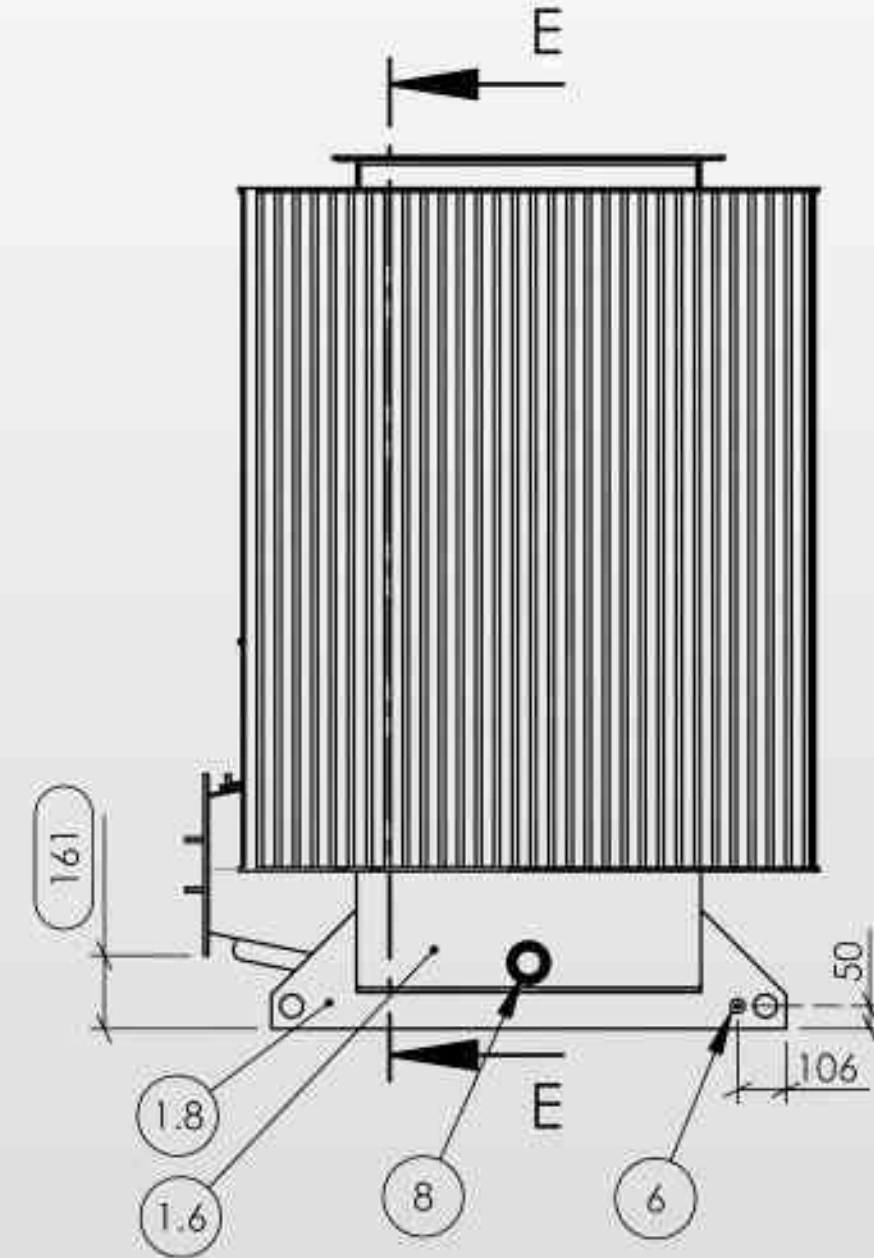



Material: S235JR, S235J0, S235J2, S355JR, S355J0, S355J2+N, SS304, SS316L, DC01

Surface Treatment: RAL color codes are specified by the customer, UL certified on demand coatings

Corrosion Protection: Coatings can be applied within the range of C3-L to C5-VH.

Welding Technique: MIG/MAG, TIG, Spot

Panel Heights: 400 and 1,600 mm

Fin pitch: 45 mm (minimum 35 mm upon request)

Capacity: 1200 tons/month

Cable Boxes

Cable boxes are metal enclosures used in electrical transformer and power distribution systems to provide secure connection points for incoming and outgoing power cables. They protect cable terminations and electrical connections from environmental conditions, mechanical damage, moisture, and dust. Cable boxes are designed to ensure safe insulation, reliable electrical performance, and easy access for installation and maintenance operations. Depending on the application, they may include bushings, terminal arrangements, sealing systems, and grounding components.

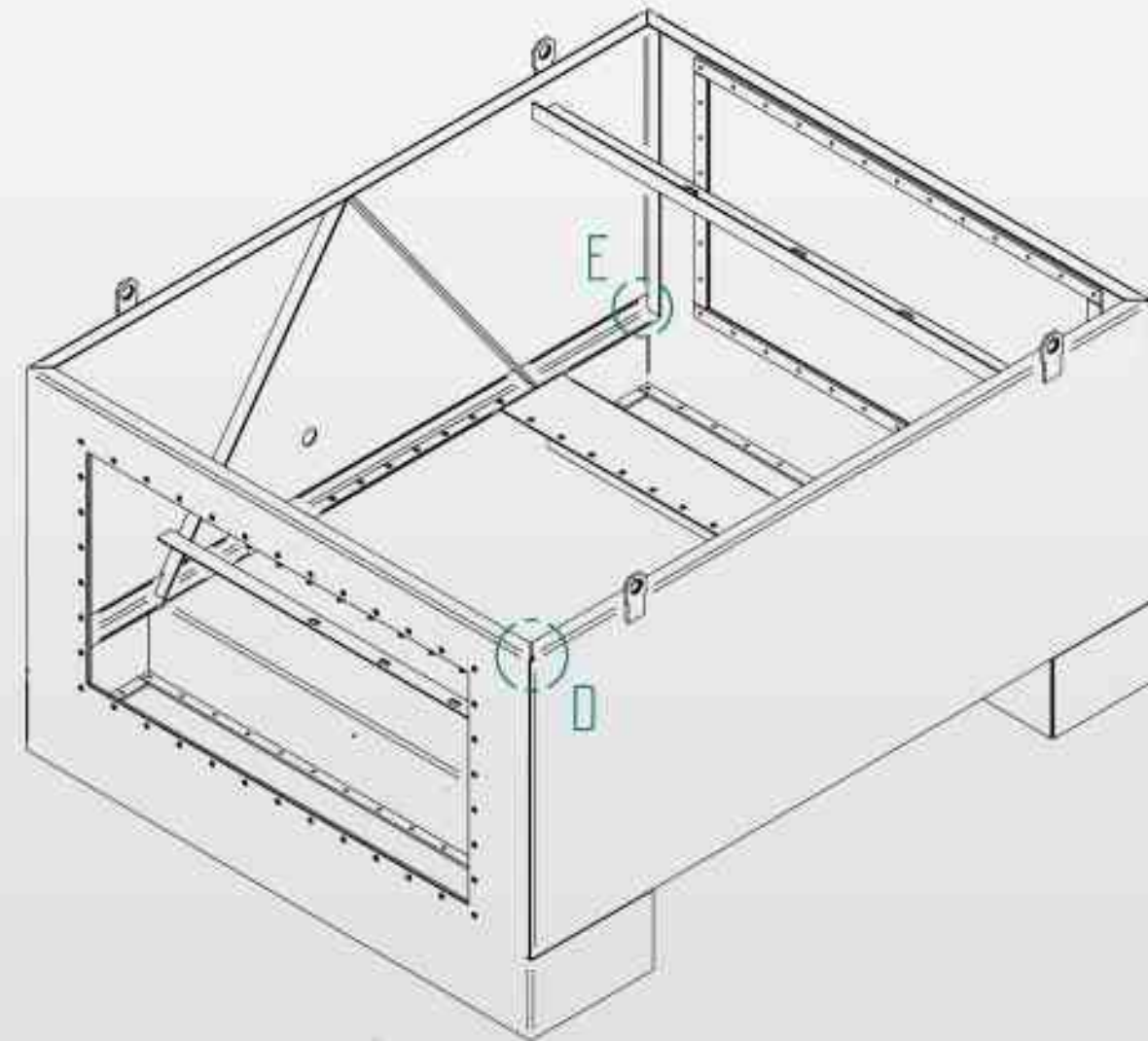



Material: S235JR, S235JO, S235J2, S355JR, S355JO, S355J2+N, SS304, SS316L

Surface Treatment: RAL color codes are specified by the customer, UL certified on demand coatings

Corrosion Protection: Coatings can be applied within the range of C3-L to C5-VH.

Welding Technique: MIG/MAG, TIG

Weight: Up to 500 kg

Capacity: 2 tons/month

Conservatories Tanks

Conservatories tanks are auxiliary components used in oil-filled transformers to accommodate the expansion and contraction of insulating oil caused by temperature variations during operation. They help maintain proper oil levels inside the transformer while minimizing direct contact between the insulating oil and ambient air, reducing moisture absorption and oxidation. Conservatories tanks are typically connected to the main transformer tank through piping systems and may include accessories such as oil level indicators, dehydrating breathers, and protection devices.

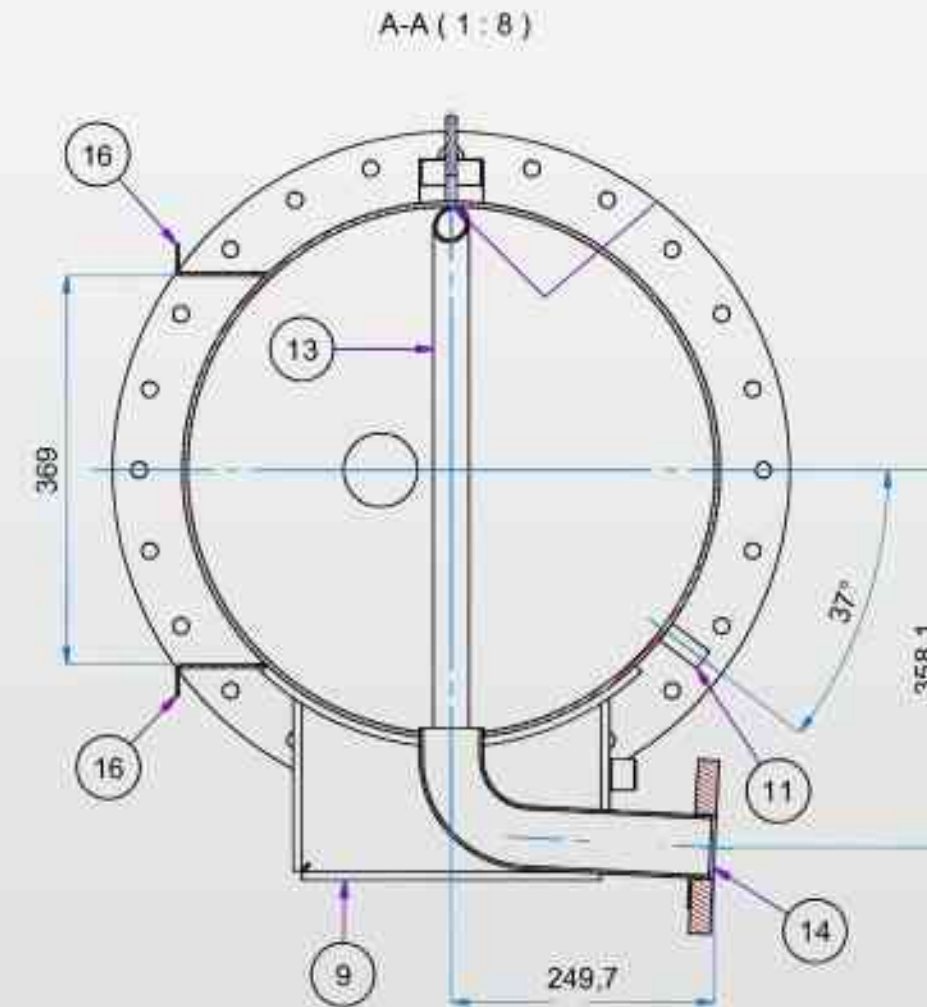



Material: S235JR, S235J0, S235J2, S355JR, S355J0, S355J2+N, SS304, SS316L

Surface Treatment: RAL color codes are specified by the customer, UL certified on demand coatings

Corrosion Protection: Coatings can be applied within the range of C3-L to C5-VH.

Welding Technique: MIG/MAG, TIG

Weight: Up to 400 kg

Capacity: 5 tons/month

Production Process

DESIGN. The design process of transformer tanks is carried out according to customer requirements, international standards, and transformer operating conditions. Detailed manufacturing drawings and quality documentation are prepared before production begins.



CUTTING-BENDING. High-quality metal sheets are processed using precision CNC and laser cutting technologies to achieve accurate dimensions and clean edges. The cut materials are shaped through bending operations to form tank walls, covers, frames, and structural reinforcements. Cutting and bending operations are performed in six lines.

WELDING. The prepared components are assembled and welded by certified welders using qualified welding procedures. Welding operations are performed to guarantee structural strength, leak tightness, and long-term reliability under operating conditions. Critical weld seams are inspected visually and, when required, through non-destructive testing methods. In 40 welding stations are used welding techniques such as TIG, MIG/MAG, spot.



COATING. After cleaning and shot blasting to remove contaminants and improve coating adhesion, protective primer and paint systems are applied to provide high resistance against corrosion and environmental conditions. Coating thickness and surface quality are monitored according to customer specifications and industry standards.

QUALITY. Comprehensive quality control procedures are implemented throughout all stages of production. Dimensional inspections, weld quality checks, and leak tests are performed to verify compliance with technical specifications and standards.



Our Approach to Quality

- To guarantee complete control of welding operations, material traceability, and documented compliance, ADS Metal implements a quality system certified to ISO 9001 and ISO 3834-2.
- ADS Metal has extensive experience with PPAP documentation, enabling us to meet customer requirements for part approvals, initial sample inspections, and change control.
- The quality team at ADS Metal continuously tracks Key Performance Indicators (KPIs) and performs Process FMEAs to assess and mitigate potential production risks, maintaining consistent process reliability.
- Our evolving ERP-based quality module facilitates non-conformity tracking, corrective actions, and audit-ready documentation, reinforcing our commitment to transparency and continuous improvement.
- ADS Metal's quality system has been successfully audited by leading OEMs, and by independent certification bodies, confirming our ability to comply with the highest quality requirements.



Certificates and Approvals



New Investment

Our new facility construction at Anadolu OSB has been launched in late April, 2026.

Prospective Launch Date:

Second quarter of 2027

Employment Objective:

Up to 100 new jobs

Crane Capacity:

Up to 40 tons

Indoor and Outdoor Production Area:

17,935 m²

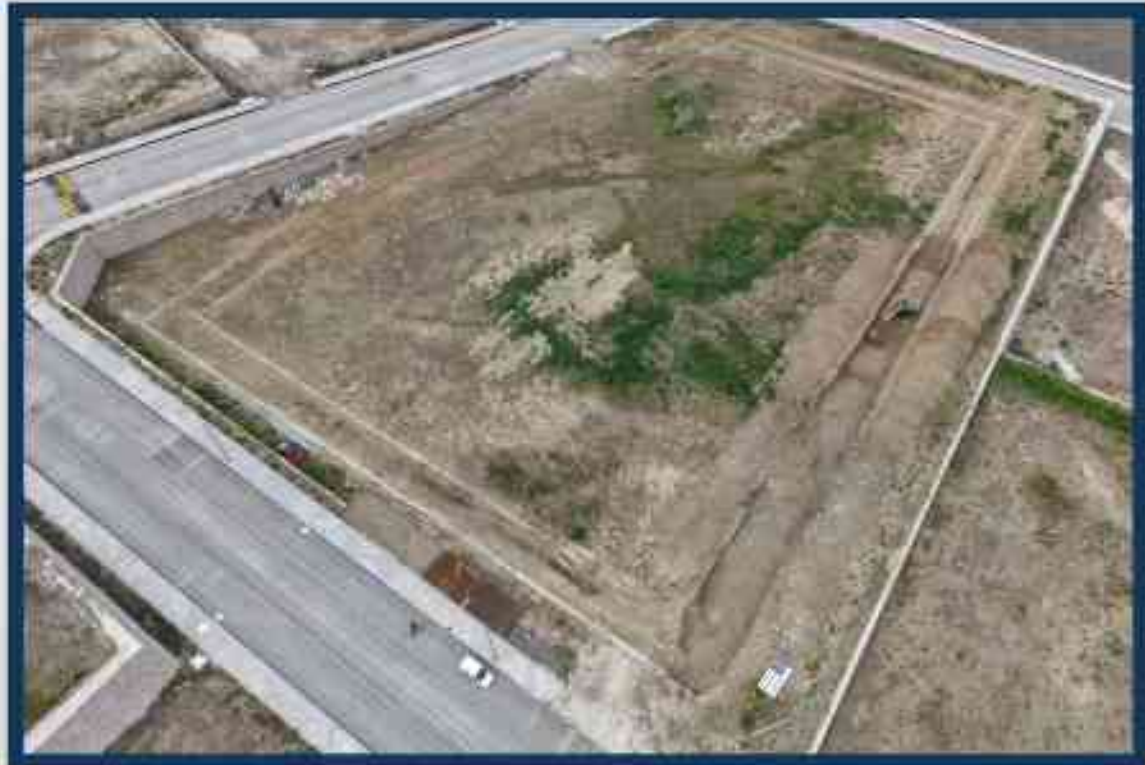



Anadolu Industrial Zone, 18. Str. No: 2
Malıköy - Sincan - Ankara / TÜRKİYE

Baskent Industrial Zone, Baskent Boulevard No: 96
Malıköy - Sincan Ankara / TÜRKİYE



+90 544 815 23 19
+90 533 575 94 48



www.adsmetal.com.tr



sales@adsmetal.com.tr

